

Wkręt metryczny
łeb stożkowo-soczewkowy
z nacięciem krzyżowym

DIN 966
PN/M-82212
ISO 7047

Materiał: stal, A2

Powłoka ochronna: ocynk

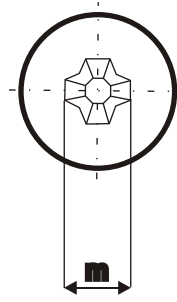
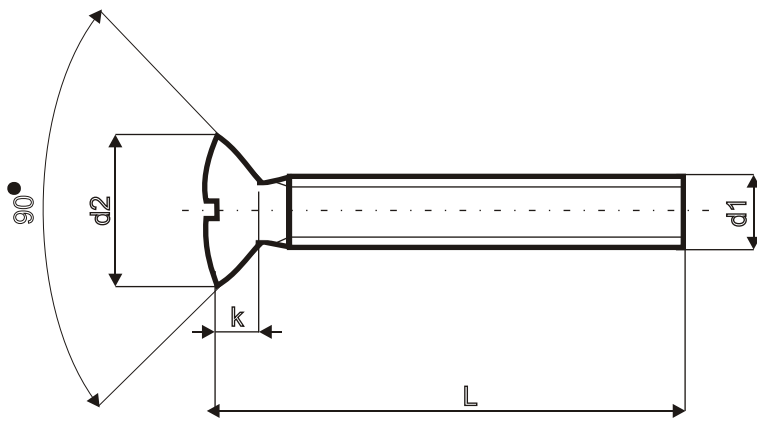

d1	M 2	M 2,5	M 3	M 4	M 5	M 6	M 8
d2	3,8	4,7	5,6	7,5	9,2	11	14,5
k max.	1,2	1,5	1,65	2,2	2,5	3	4
m	2,5	2,7	3,1	4,5	5,3	6,8	9

d1 mm	L mm	stal ocynkowana 096652	A2 096620
M 2	4,0	020-004	
	5,0	020-005	
	6,0	020-006	
	8,0	020-008	
M 2,5	5,0	025-005	
	6,0	025-006	025-006
	8,0	025-008	025-008
	10,0	025-010	025-010
	12,0	025-012	025-012
M 3	5,0	030-005	030-005
	6,0	030-006	030-006
	8,0	030-008	030-008
	10,0	030-010	030-010
	12,0	030-012	030-012
	14,0	030-014	030-014
	16,0	030-016	030-016
	18,0	030-018	030-018
	20,0	030-020	030-020
	25,0	030-025	030-025
	30,0	030-030	030-030
	35,0	030-035	
M 4	6,0	040-006	040-006
	8,0	040-008	040-008
	10,0	040-010	040-010
	12,0	040-012	040-012
	16,0	040-016	040-016
	18,0	040-018	040-018
	20,0	040-020	040-020
	25,0	040-025	040-025
	30,0	040-030	040-030
	40,0	040-040	040-040
50,0	040-050	040-050	

d1 mm	L mm	stal ocynkowana 096652	A2 096620
M 5	8,0	050-008	050-008
	10,0	050-010	050-010
	12,0	050-012	050-012
	14,0	050-014	050-014
	16,0	050-016	050-016
	20,0	050-020	050-020
	25,0	050-025	050-025
	30,0	050-030	050-030
	35,0	050-035	050-035
	40,0	050-040	050-040
	45,0	050-045	050-045
	50,0	050-050	050-050
M 6	60,0	050-060	050-060
	70,0	050-070	050-070
	80,0	050-080	050-080
	10,0	060-010	060-010
	12,0	060-012	060-012
	14,0	060-014	
	16,0	060-016	060-016
	18,0	060-018	
	20,0	060-020	060-020
	25,0	060-025	060-025
	30,0	060-030	060-030
	35,0	060-035	060-035
M 8	40,0	060-040	060-040
	50,0	060-050	060-050
	60,0	060-060	060-060
	80,0	060-080	060-080
	16,0	080-016	080-016
	20,0	080-020	080-020
	25,0	080-025	080-025
	30,0	080-030	080-030
35,0	080-035	080-035	
40,0	080-040	080-040	